



MONTERO

PRETENSADOS Y EXCAVACIONES, S.L.
37497 GALLEGOS DE ARGANÁN (SALAMANCA)
Fijo 923 47 72 30 Móvil 689 76 23 99
Fabrica 923 47 72 55 Fax 923 47 70 90
WWW.MONTERO-SL.COM



Arqueta 100

Pesos:

Tapa con Marco	390 kg
Realte	675 kg
Arqueta sin Fondo	1000 kg
Arqueta con Fondo	1250 kg

Cotas:

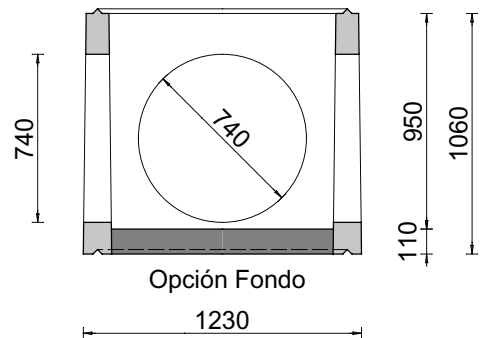
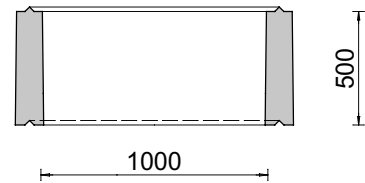
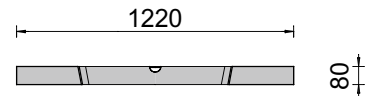
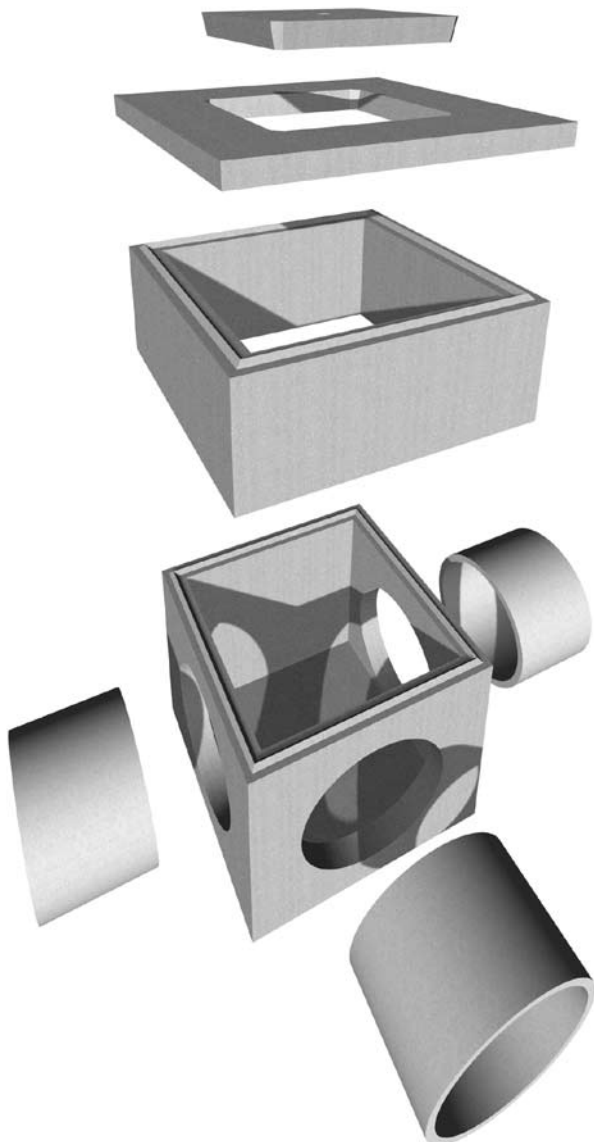

Escala 1/33 $\frac{1}{3}$
Cotas en mm

