

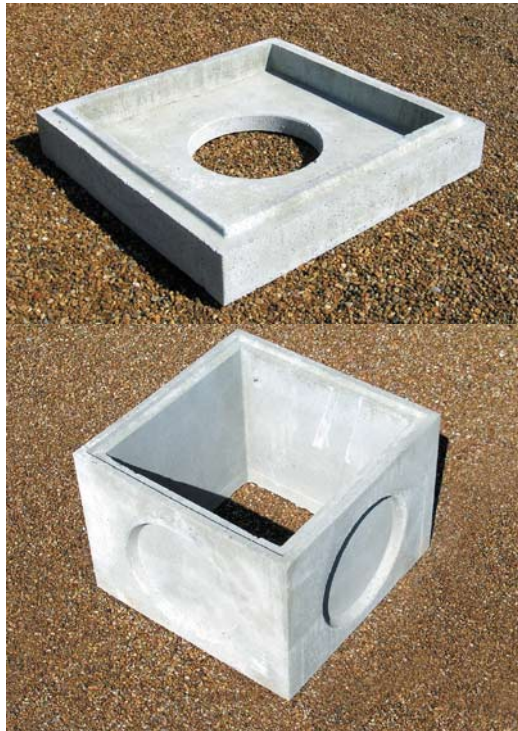

MONTERO

PRETENSADOS Y EXCAVACIONES, S.L.
37497 GALLEGOS DE ARGANÁN (SALAMANCA)
Fijo 923 47 72 30 Móvil 689 76 23 99
Fabrica 923 47 72 55 Fax 923 47 70 90
WWW.MONTERO-SL.COM



Arqueta 120

Pesos:

Tapa	520 kg
Realte	680 kg
Arqueta sin Fondo	1415 kg
Arqueta con Fondo	1750 kg

Cotas:

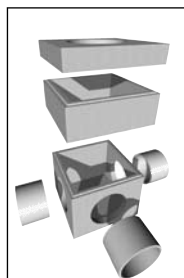
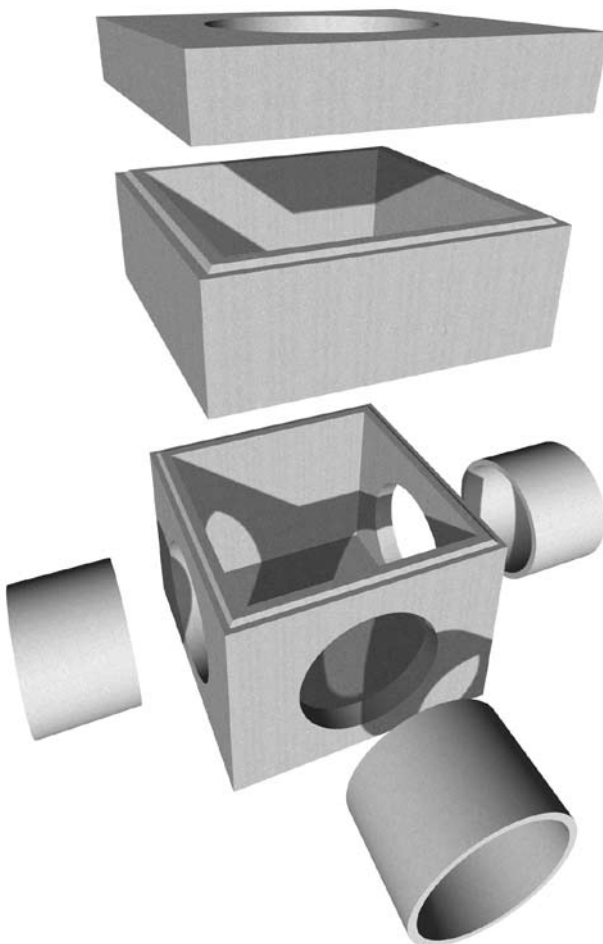
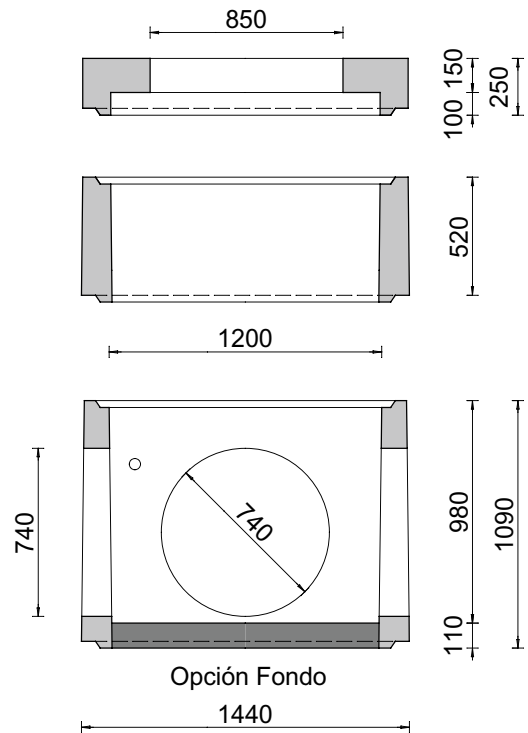

Escala 1/33 $\frac{1}{3}$
Cotas en mm