



**MONTERO**  
PRETENSADOS Y EXCAVACIONES, S.L.  
37497 GALLEGOS DE ARGANÁN (SALAMANCA)  
Fijo 923 47 72 30 Móvil 689 76 23 99  
Fabrica 923 47 72 55 Fax 923 47 70 90  
**WWW.MONTERO-SL.COM**



## Imbornal

con Reja fundición abatible  
con Reja fundición concava  
sin Reja

Pesos:

Imbornal sin Fondo 254 kg  
Imbornal con Fondo 280 kg  
Imbornal Sifónica 295 kg

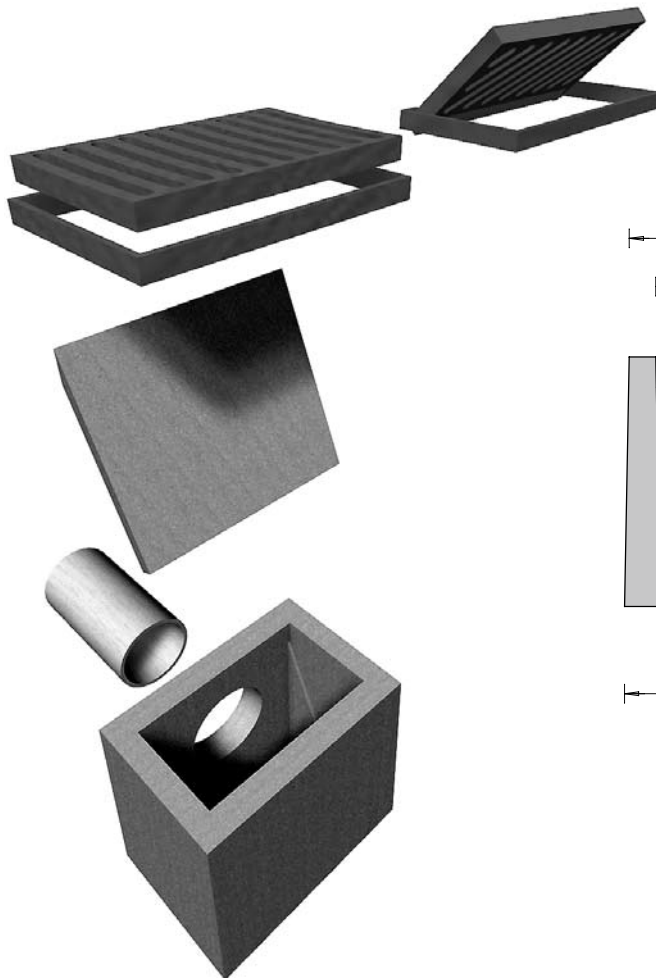

Cotas:

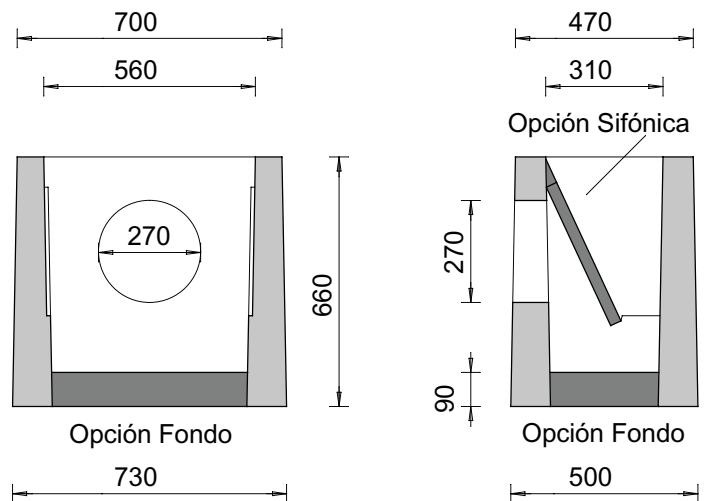

Escala 1/20  
Cotas en mm

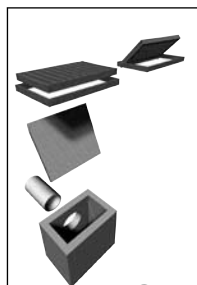

**24**